

# RAM INDUSTRIES TEST REPORT

## SCOPE OF WORK

AAMA/WDMA/CSA 101/I.S.2/A440 TESTING ON SERIES S800 INSIDE GLAZED TWIN HEAVY PICTURE WINDOW

## REPORT NUMBER

J3067.01-801-44-R0

## TEST DATE(S)

01/17/19

## ISSUE DATE

03/05/19

## RECORD RETENTION END DATE

01/17/23

## PAGES

13

## DOCUMENT CONTROL NUMBER

RT-R-AMER-Test-2804 (04/17/18)

© 2017 INTERTEK

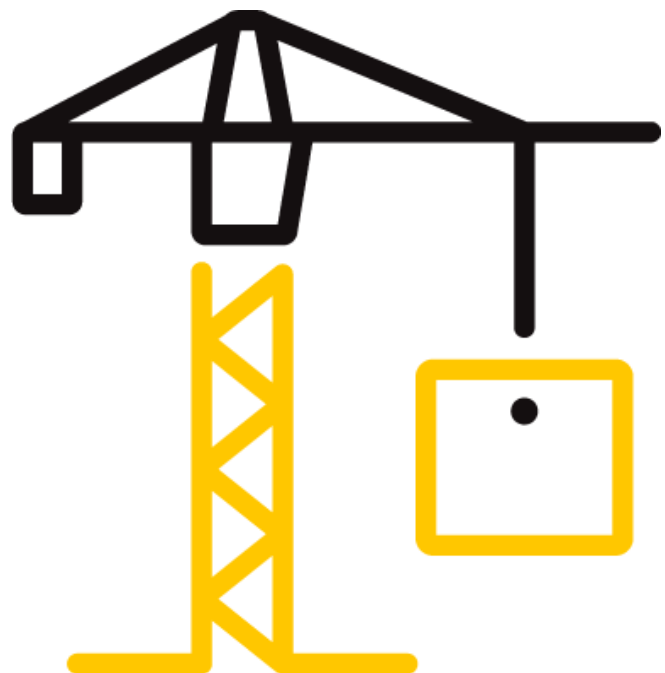

## TEST REPORT FOR RAM INDUSTRIES

Report No.: J3067.01-801-44-r0

Date: 03/05/19

### REPORT ISSUED TO

#### RAM INDUSTRIES

8600 Commerce Park Dr.  
Houston, TX 77036

### SECTION 1

#### SCOPE

Intertek Building & Construction (B&C) was contracted by Ram Industries to perform testing in accordance with AAMA/WDMA/CSA 101/I.S.2/A440 on their Series S800 Outside Glazed Twin Heavy Picture Window. Results obtained are tested values and were secured by using the designated test methods. Testing was conducted at the Intertek test facility in Plano, TX. This report does not constitute certification of this product nor an opinion or endorsement by this laboratory.

### SECTION 2

#### SUMMARY OF TEST RESULTS

TITLE	RESULTS
AAMA/WDMA/CSA 101/I.S.2/A440-17	CW-PG30-FW
Design Pressure	±1440 Pa (±30.08 psf)
Air Infiltration	0.15 L/s/m <sup>2</sup> (0.03 cfm/ft <sup>2</sup> )
Water Penetration Resistance Test Pressure	580 Pa (12.03 psf)

Reference must be made to Intertek B&C Report No. J3067.01-801-44, dated 02/25/19 for complete test specimen description and detailed test results.

For INTERTEK B&C:

<b>COMPLETED BY:</b>	Jeffrey Crump	<b>REVIEWED BY:</b>	Andy Cost
<b>TITLE:</b>	Sr. Project Manager – AWS	<b>TITLE:</b>	Laboratory Manager
<b>SIGNATURE:</b>		<b>SIGNATURE:</b>	
<b>DATE:</b>	03/05/19	<b>DATE:</b>	03/05/19

JC:cm

This report is for the exclusive use of Intertek's Client and is provided pursuant to the agreement between Intertek and its Client. Intertek's responsibility and liability are limited to the terms and conditions of the agreement. Intertek assumes no liability to any party, other than to the Client in accordance with the agreement, for any loss, expense or damage occasioned by the use of this report. Only the Client is authorized to permit copying or distribution of this report and then only in its entirety. Any use of the Intertek name or one of its marks for the sale or advertisement of the tested material, product or service must first be approved in writing by Intertek. The observations and test results in this report are relevant only to the sample(s) tested. This report by itself does not imply that the material, product, or service is or has ever been under an Intertek certification program.

## TEST REPORT FOR RAM INDUSTRIES

Report No.: J3067.01-801-44-r0

Date: 03/05/19

### SECTION 3

#### TEST SPECIFICATION(S)/METHODS

The specimens were evaluated in accordance with the following:

**AAMA/WDMA/CSA 101/I.S.2/A440-17**- *North American Fenestration Standard/Specification for Windows, Doors, and Skylights*

The following test methods were used during testing:

**AAMA 205-15**, *In-Plant Testing Guidelines for Manufacturers and Independent Laboratories*

**ASTM E283-04(2012)**, *Standard Test Method for Determining Rate of Air Leakage Through Exterior Windows, Curtain Walls, and Doors Under Specified Pressure Differences Across the Specimen*

**ASTM E330/E330M-14**, *Standard Test Method for Structural Performance of Exterior Windows, Doors, Skylights and Curtain Walls by Uniform Static Air Pressure Difference*

**ASTM E547-00(2016)**, *Standard Test Method for Water Penetration of Exterior Windows, Skylights, Doors, and Curtain Walls by Cyclic Static Air Pressure Difference*

**ASTM F588-17**, *Standard Test Methods for Measuring the Forced Entry Resistance of Window Assemblies, Excluding Glazing Impact*

## TEST REPORT FOR RAM INDUSTRIES

Report No.: J3067.01-801-44-r0

Date: 03/05/19

### SECTION 4

#### MATERIAL SOURCE/INSTALLATION

Test specimens were provided by the client. Representative samples of the test specimen(s) will be retained by Intertek B&C for a minimum of four years from the test completion date.

The specimen was installed into a Pine wood buck. The rough opening allowed for a 1/8" shim space and the exterior perimeter of the specimen was sealed to the test buck. Installation of the tested product was performed by the client.

LOCATION	ANCHOR DESCRIPTION	ANCHOR SPACING
Interior perimeter of frame nail fin	Nail fin specimen installed in a (2" x 6") yellow pine wood test buck with #6 x 1-1/4" hex head screws which is attached to outer (2" x 10") yellow pine wood wrap. Interior of nail fin is supported by (2" x 4") yellow pine which is not attached.	Hex head screws attached 2" from each frame end and 12" on center at frame head, sill and jambs.

### SECTION 5

#### EQUIPMENT

Calibration of test equipment was performed by Intertek B&C in accordance with AAMA 205-15.

### SECTION 6

#### LIST OF OFFICIAL OBSERVERS

NAME	COMPANY
Jeff Ashcraft	Ram Industries
John Blattel	Ram Industries
Jeffrey Crump	Intertek B&C

## TEST REPORT FOR RAM INDUSTRIES

Report No.: J3067.01-801-44-r0

Date: 03/05/19

### SECTION 7

#### TEST SPECIMEN DESCRIPTION

**Product Type:** Inside Glazed Fixed Window

**Series/Model:** S840 Twin Heavy Picture Window

**Product Size(s):**

#### Test Specimen #1

OVERALL AREA:	WIDTH		HEIGHT	
	millimeters	inches	millimeters	inches
0.0 m <sup>2</sup> (00.0 ft <sup>2</sup> )				
Overall size	2880	60	2489	98
Daylight Opening	686	27	2413	95

#### Frame Construction:

MEMBER	MATERIAL	DESCRIPTION
Head, sill and jambs	Aluminum	Extruded aluminum thermally broken with polyurethane break at frame head, sill and jambs.
	JOINERY TYPE	DETAIL
All corners and mullion	Mechanical	Frame corners are attached with two (2) #8 x 1" HX WSHR Type A SMA, each. Aluminum frame corner bracket (2" x .062" thick) located at frame interior pocket. Frame vertical mullion attached with four (4) #8 x 1" HX WSHR Type A SMA. All corners sealed.

**Reinforcement:** *No reinforcement was utilized.*

**Weatherstripping:** *No weatherstripping was utilized.*

**Glazing:** *No conclusions of any kind regarding the adequacy or inadequacy of the glass in any glazed test specimen(s) can be made.*

GLASS TYPE	SPACER TYPE	INTERIOR LITE	EXTERIOR LITE	GLAZING METHOD
1" IG	Aluminum	3/16" annealed	3/16" annealed	Interior glazed with 1/16" x 3/8" glazing tape at the exterior face of glass and aluminum glazing bead with rubber stop at the interior face of glass.

**TEST REPORT FOR RAM INDUSTRIES**

Report No.: J3067.01-801-44-r0

Date: 03/05/19

LOCATION	QUANTITY	DAYLIGHT OPENING		GLASS BITE
		millimeters	inches	
Head sill and jambs	4	686 x 2413	27 x 95	9/16

**Drainage:** *Weeps were not utilized.*

**Hardware:** *No hardware was utilized.*

**SECTION 8  
TEST RESULTS**

The temperature during testing was 23°C (73°F). The results are tabulated as follows:

TITLE OF TEST	RESULTS	ALLOWED	NOTE
<b>Air Leakage,</b> Infiltration per ASTM E283 at 75 Pa (1.57 psf)	0.15 L/s/m <sup>2</sup> (0.03 cfm/ft <sup>2</sup> )	1.5 L/s/m <sup>2</sup> (0.3 cfm/ft <sup>2</sup> ) max.	1, 2
<b>Water Penetration,</b> per ASTM E547 at 220 Pa (4.59 psf)	Pass	No leakage	
<b>Uniform Load Deflection,</b> per ASTM E330 Deflections taken at anchors +1440 Pa (+30.08 psf) -1440 Pa (-30.08 psf)	11 mm (0.43") 11 mm (0.42")	14 mm (0.54") max. 14 mm (0.54") max.	
<b>Uniform Load Structural,</b> per ASTM E330 Permanent set taken at anchors +2160 Pa (+45.11 psf) -2160 Pa (-45.7 psf)	0.50 mm (0.02") 0.50 mm (0.02")	1 mm (0.29") max. 1 mm (0.29") max.	
<b>Forced Entry Resistance,</b> per ASTM F588, Type: A - Grade: 10	Pass	No entry	

## TEST REPORT FOR RAM INDUSTRIES

Report No.: J3067.01-801-44-r0

Date: 03/05/19

*Note 1: The tested specimen meets (or exceeds) the performance levels specified in AAMA/WDMA/CSA 101/I.S.2/A440 for air leakage resistance.*

*Note 2: Test Date 01/17/19 / Time: 10:00 AM(Air Note Only)*

*Note 3: The client opted to start at a pressure higher than the minimum required. Test results are reported under Optional Performance.*

*Note 4: The deflections reported are not limited by AAMA/WDMA/CSA 101/I.S.2/A440 for this product designation. The deflection data is recorded in this report for special code compliance and information only.*

*Note 5: Loads were held for 10 seconds.*

*Note 6: Tape and film were not used to seal against air leakage during structural testing. In our opinion, the tape and film did not influence the results of the test.*

## TEST REPORT FOR RAM INDUSTRIES

Report No.: J3067.01-801-44-r0

Date: 03/05/19

### SECTION 9

#### LOCATION OF AIR SEAL

The air seal between the test specimen and the test wall is detailed below. The seal is made of foam weatherstripping and is attached to the edge of the test specimen buck. The test specimen buck is placed against the test wall and clamped in place, compressing the weatherstripping and creating a seal.

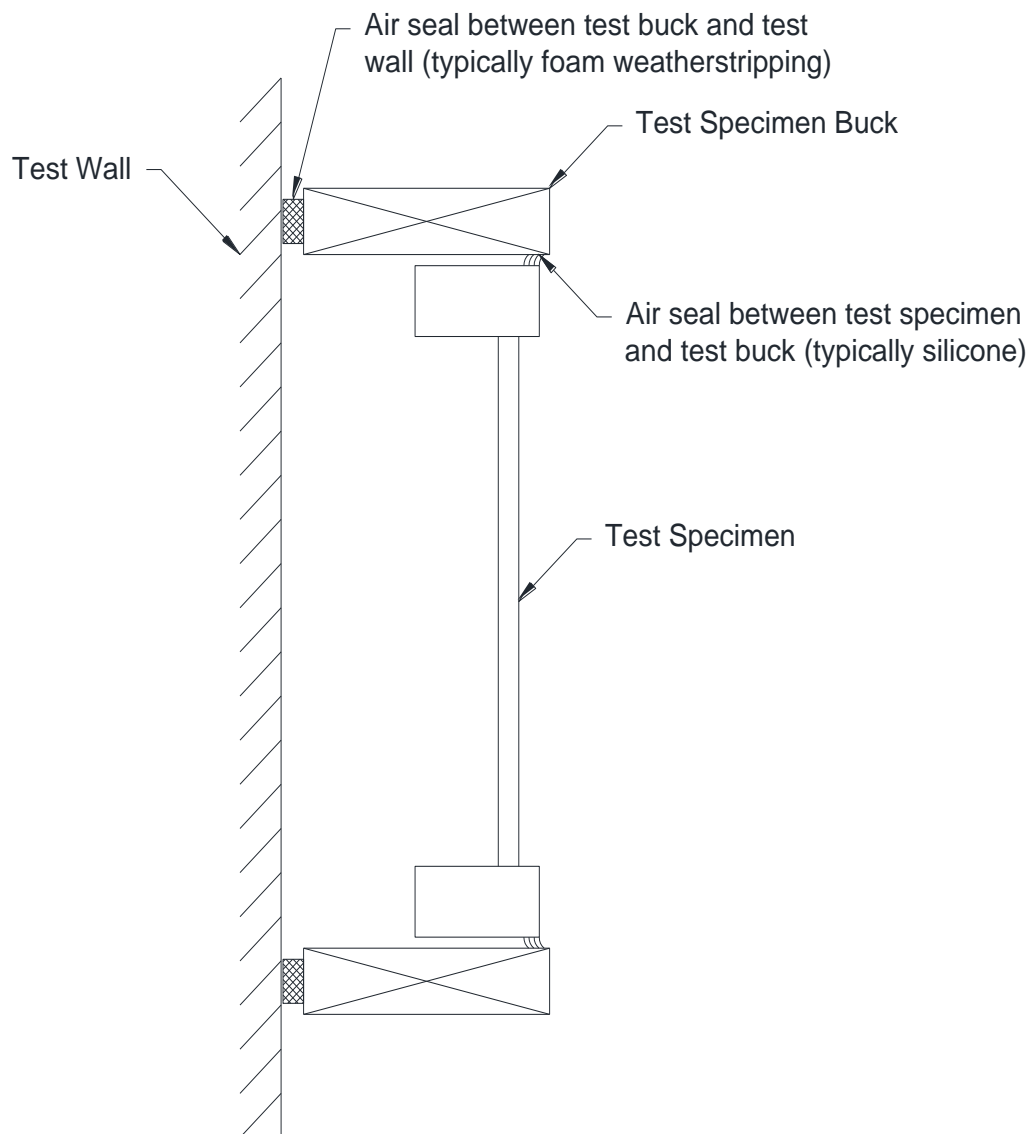





Total Quality. Assured.

## TEST REPORT FOR RAM INDUSTRIES

Report No.: J3067.01-801-44-r0

Date: 03/05/19

1909 10th Street, Suite 100  
Plano, Texas 75074

Telephone: 469-814-0687  
[www.intertek.com/building](http://www.intertek.com/building)

### SECTION 10

#### CONCLUSION

The specimen tested successfully met the performance requirements for a **CW-PG30-FW** rating.

Reference Intertek B&C Report No. J3067.010-801-44, dated 02/25/19 for complete *Gateway* test specimen description and test results.



Total Quality. Assured.

## TEST REPORT FOR RAM INDUSTRIES

Report No.: J3067.01-801-44-r0

Date: 03/05/19

1909 10th Street, Suite 100  
Plano, Texas 75074

Telephone: 469-814-0687  
[www.intertek.com/building](http://www.intertek.com/building)

### SECTION 11 DRAWINGS

The test specimen drawings have been reviewed by Intertek B&C and are representative of the test specimen(s) reported herein. Test specimen construction was verified by Intertek B&C per the drawings included in this report. Any deviations are documented herein or on the drawings.

# Ram S840 Heavy Picture

**DRAWING APPROVAL**

APPROVED  
 APPROVED AS NOTED  
 REVISE AND RESUBMIT

SIGN \_\_\_\_\_ DATE \_\_\_\_\_

Please return one print set marked with your signature, any comments, and notation of approval for fabrication.

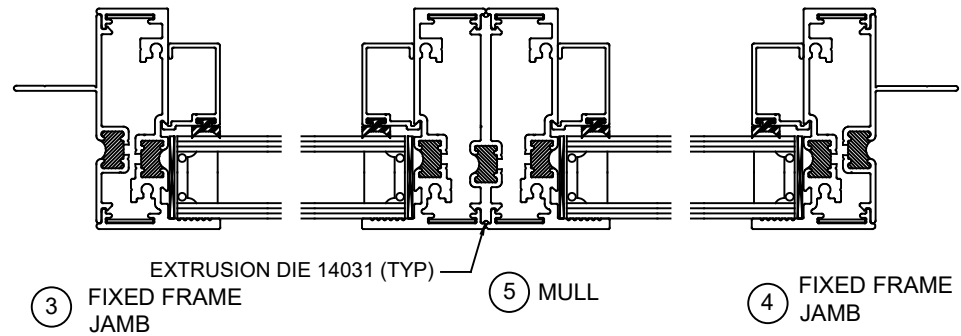
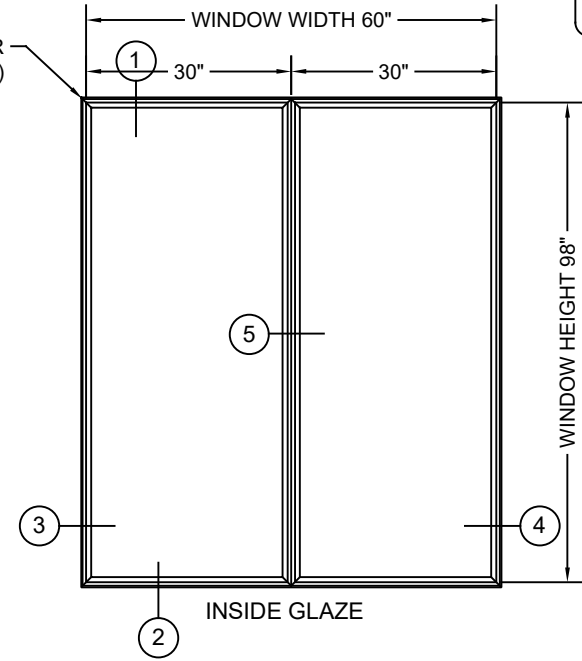
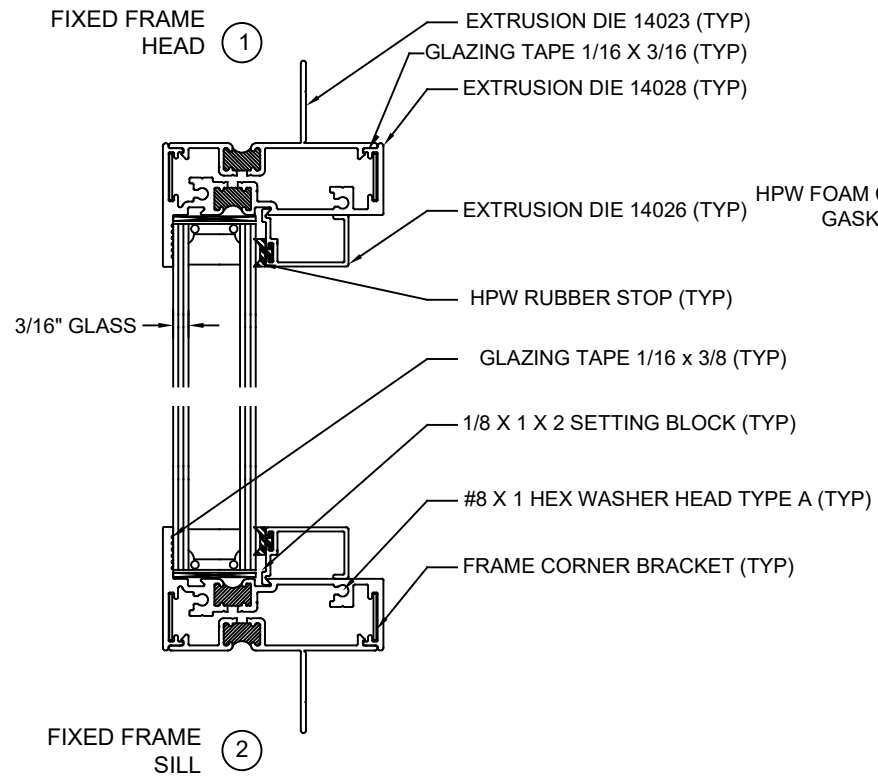

	Report #:	J3067.01-801-44
	Date:	03/05/19
	Verified by:	J.Crump

PROPRIETARY AND CONFIDENTIAL

THE INFORMATION CONTAINED IN THIS DRAWING IS THE SOLE PROPERTY OF RAM INDUSTRIES. ANY REPRODUCTION IN PART OR AS A WHOLE WITHOUT THE WRITTEN PERMISSION OF RAM INDUSTRIES IS PROHIBITED.



REV	DESCRIPTION	BY	DATE
	LEAD TIME	10-12	WEEKS
	GLASS WARRANTY	2	YEARS
	FRAME WARRANTY	2	YEARS
	FINISH WARRANTY	2	YEARS
	U-FACTOR		OUTER GLASS
	SHGC		AIR SPACE
	DA GLASS THICKNESS		INNER GLASS

UNLESS OTHERWISE SPECIFIED		NAME	DATE
DIMENSIONS ARE IN INCHES		JSA	11/26/2018
TOLERANCES:			
FRACTIONAL			
ANGULAR: MACH/BEND		MARK	A
TWO PLACE DECIMAL		QTY.	2
THREE PLACE DECIMAL		FINISH	---
MATERIAL		DP	
6063-T5 ALUMINUM		COMMENTS:	
DD NOT SCALE DRAWING			

RAM INDUSTRIES	
TITLE:	
S840 HPW TWIN	
SIZE/DWG. NO.	REV
A/RAM-HPW 1 LT	
SCALE:	SHEET 1 OF 1

- ☆ MINOR DEFECTS ON RUN OUT SURFACE MAY NOT BE REASON FOR REJECTION.
- \* STRUCTURAL AND/OR HEAT STREAKS ARE POSSIBLE IN THIS AREA AND MAY NOT BE REASON FOR REJECTION.
- ↑ LIGHT PAINT COVERAGE TO BE EXPECTED IN THIS AREA AND MAY NOT BE REASON FOR REJECTION.

<b>intertek</b> Total Quality Assured.	Report #:	J3067.01-801-44
	Date:	03/05/19
	Verified by:	J.Crump

**APPROVAL PRINT**

A. PLEASE INDICATE ANY EXPOSED SURFACES.  
 B. PLEASE MARK CLEARLY ANY CORRECTIONS OR REVISIONS YOU FEEL ARE NECESSARY.  
 C. PLEASE SIGN & DATE ON THE LINE BELOW INDICATING YOUR APPROVAL AS IS, OR WITH YOUR MARKED CHANGES.  
 D. PLEASE EXPEDITE THIS APPROVAL, DELAY IN YOUR APPROVAL MAY RESULT IN A DELAY OF YOUR MATERIAL ORDER.

[Signature]      6-6-2018  
 APPROVED      DATE

DIE NO.	14023
7" PRESS	
BKR. NO.	10X3
BOLS. NO.	
FDR. PLT.	10X1
EXT. RATIO	
.010 R.-(°) (4)	
.020 R.-(°) (2)	
.025 R.-(°) (12)	
.062 R.-(°) (4)	
FULL R.-(°) (3)	

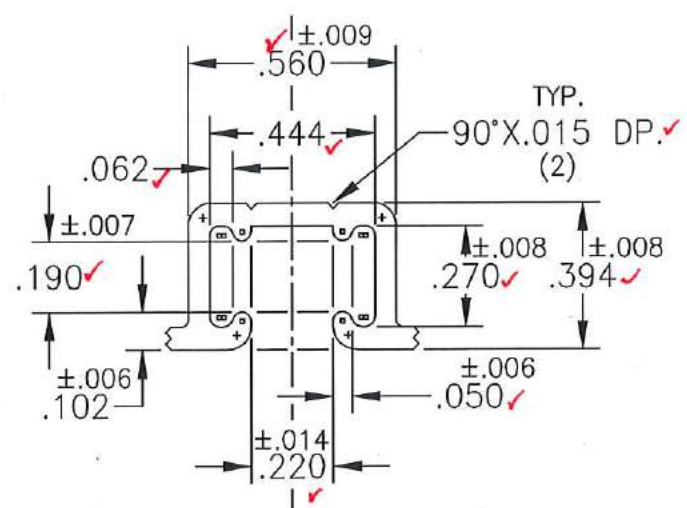
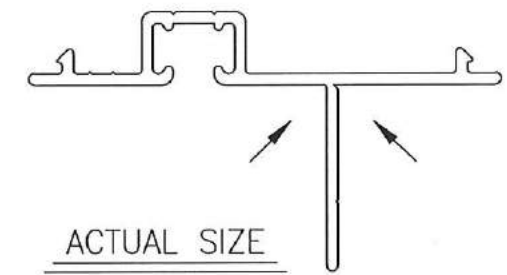
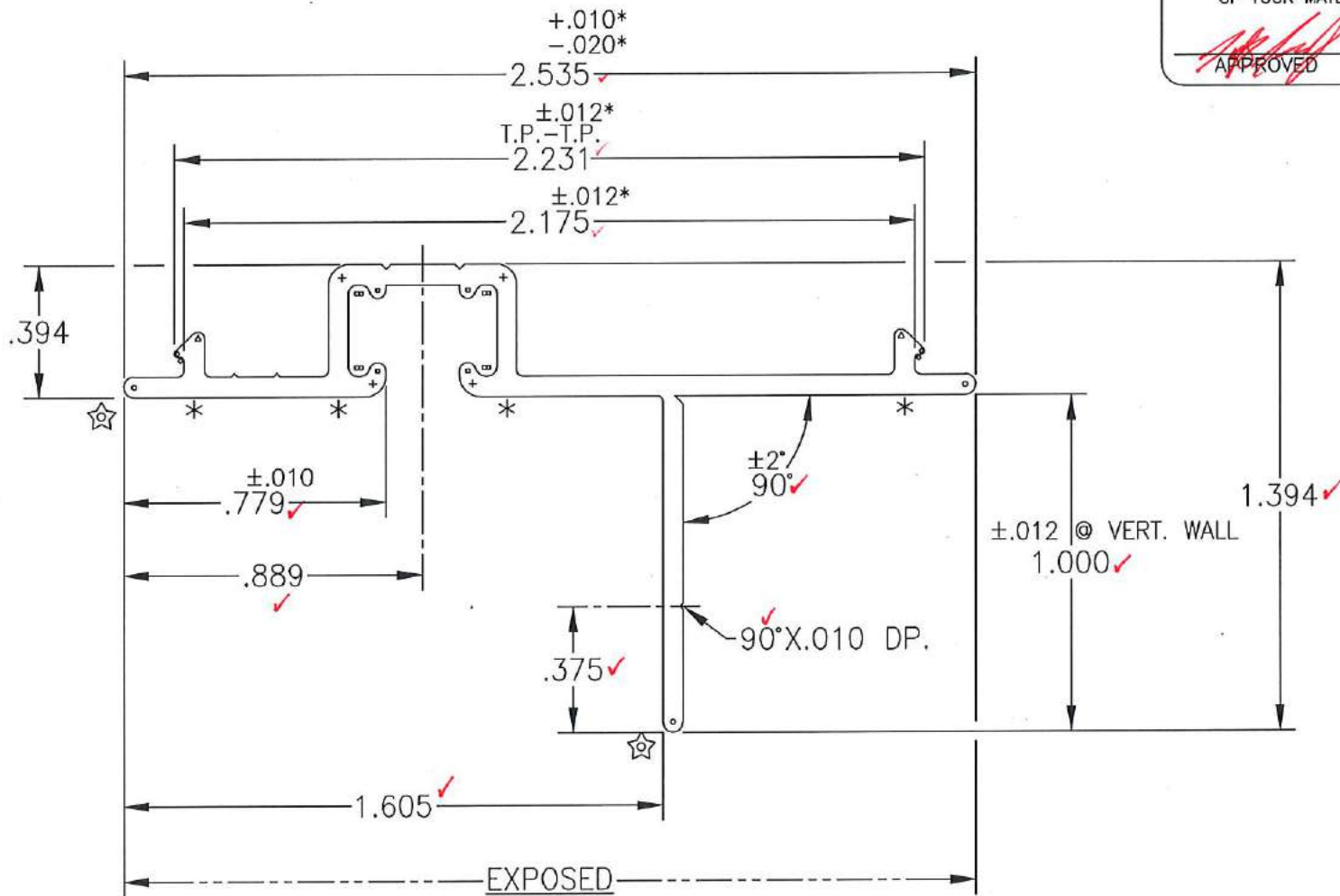
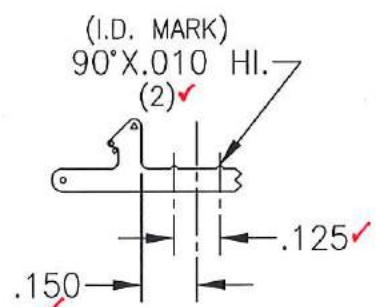
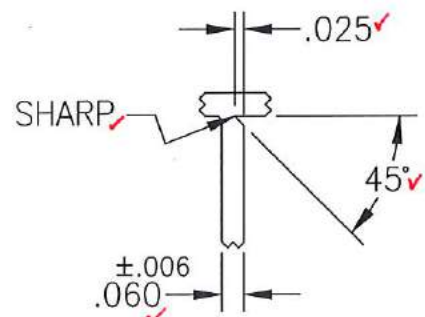
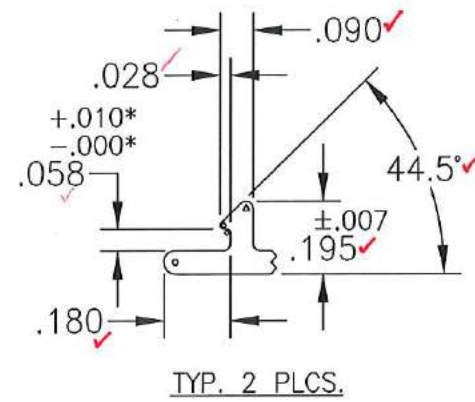

- NOTES: ±.006
1. .062 TYP. WALL THKN. EXCEPT AS NOTED.
  2. BREAK SHARP CORNERS AT .015 R.

REVISION							
ALUMINUM ASSOCIATION STANDARD TOLERANCES TO APPLY UNLESS OTHERWISE SPECIFIED							
EST. AREA	.289	TOTAL PERIM.	9.512	DATE:	04-23-18	DRAWN BY:	M.MARKULY
EST. WT/FT.	.347	CIRCLE SIZE	2.53	HOLES	3	PREF. PRESS	7"
OUTSIDE PERIM.	9.512	FACTOR	27	DIE SIZE	10X2	SCALE	2X F

<b>tel</b> <b>EXTRUDERS</b>	
A DIVISION OF TOWER EXTRUSIONS, LTD.	
NAME	
<b>RAM INDUSTRIES</b>	
PART NO.	DWG. NO.
	D-042318-01
END USE	
APPLIED FIN	
CLASS	ALLOY
SOLID	6063-T5
CAVITY	DIE NO.
B-B	14023

DIE NO. 14023

- ☆ MINOR DEFECTS ON RUN OUT SURFACE MAY NOT BE REASON FOR REJECTION.
- \* STRUCTURAL AND/OR HEAT STREAKS ARE POSSIBLE IN THIS AREA AND MAY NOT BE REASON FOR REJECTION.

	Report #:	J3067.01-801-44
	Date:	03/05/19
	Verified by:	J.Crump

APPROVAL PRINT

A. PLEASE INDICATE ANY EXPOSED SURFACES.  
 B. PLEASE MARK CLEARLY ANY CORRECTIONS OR REVISIONS YOU FEEL ARE NECESSARY.  
 C. PLEASE SIGN & DATE ON THE LINE BELOW INDICATING YOUR APPROVAL AS IS, OR WITH YOUR MARKED CHANGES.  
 D. PLEASE EXPEDITE THIS APPROVAL, DELAY IN YOUR APPROVAL MAY RESULT IN A DELAY OF YOUR MATERIAL ORDER.

APPROVED \_\_\_\_\_ DATE 6-6-2018

DIE NO.	14026
7" PRESS	
BKR. NO.	10X3
BOLS. NO.	
FDR. PLT.	10X1
EXT. RATIO	53.94
.010 R.-(*)	(1)
.025 R.-(*)	(4)
FULL R.-(*)	(3)

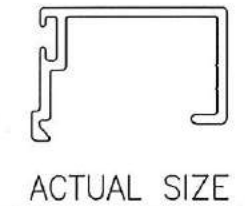
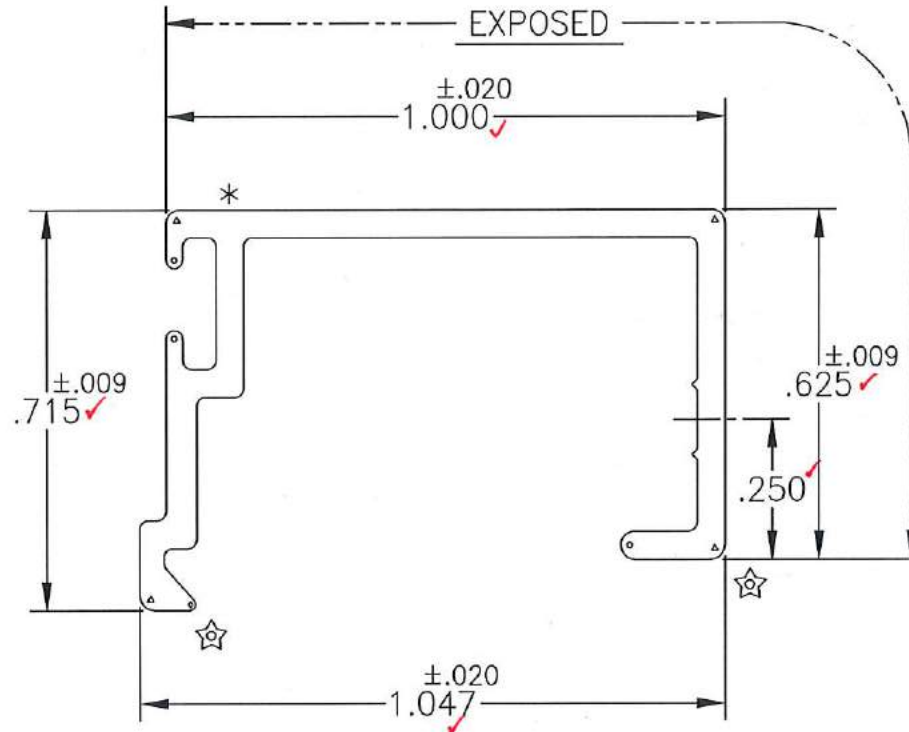
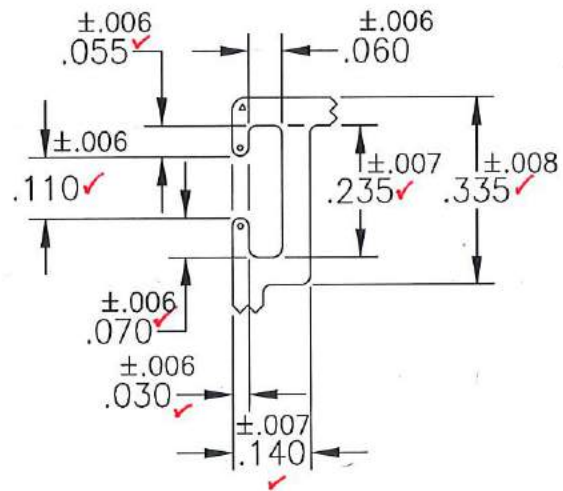

- NOTES: ±.006
- .050 TYP. WALL THKN. EXCEPT AS NOTED.
  - BREAK SHARP CORNERS AT .015 R.

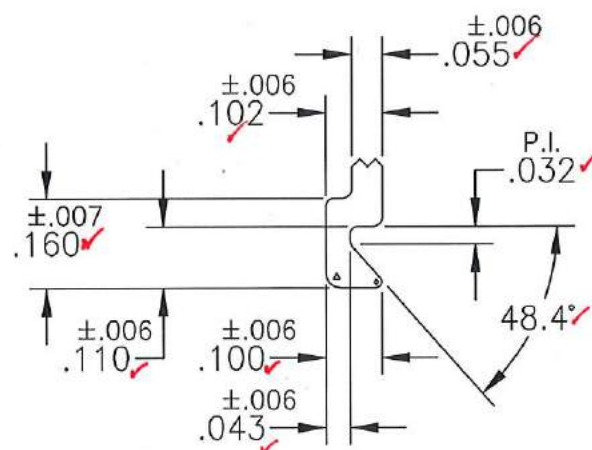
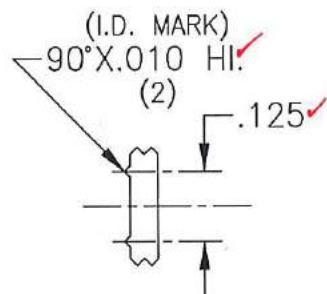

ALUMINUM ASSOCIATION STANDARD TOLERANCES TO APPLY UNLESS OTHERWISE SPECIFIED			
EST. AREA	.132	TOTAL PERIM.	5.294
EST. WT./FT.	.158	DATE:	04-23-18
OUTSIDE PERIM.	5.294	CIRCLE SIZE	1.25
		HOLES	6
		FACTOR	34
		DIE SIZE	10X2
		SCALE	3X F
 A DIVISION OF TOWER EXTRUSIONS, LTD.			
NAME			
<h2 style="margin: 0;">RAM INDUSTRIES</h2>			
PART NO.		DWG. NO.	
		D-042318-04	
END USE			
GLAZE STOP			
CLASS	SOLID	ALLOY	6063-T5
CAVITY		DIE NO.	14026

DIE NO. 14026

- ☆ MINOR DEFECTS ON RUN OUT SURFACE MAY NOT BE REASON FOR REJECTION.
- \* STRUCTURAL AND/OR HEAT STREAKS ARE POSSIBLE IN THIS AREA AND MAY NOT BE REASON FOR REJECTION.
- ↑ LIGHT PAINT COVERAGE TO BE EXPECTED IN THIS AREA AND MAY NOT BE REASON FOR REJECTION.

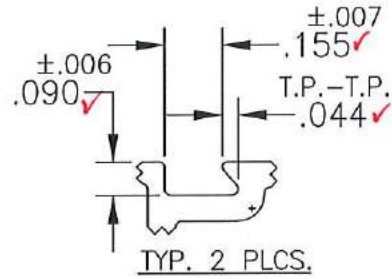

**APPROVAL PRINT**

A. PLEASE INDICATE ANY EXPOSED SURFACES.  
 B. PLEASE MARK CLEARLY ANY CORRECTIONS OR REVISIONS YOU FEEL ARE NECESSARY.  
 C. PLEASE SIGN & DATE ON THE LINE BELOW INDICATING YOUR APPROVAL AS IS, OR WITH YOUR MARKED CHANGES.  
 D. PLEASE EXPEDITE THIS APPROVAL, DELAY IN YOUR APPROVAL MAY RESULT IN A DELAY OF YOUR MATERIAL ORDER.

APPROVED *[Signature]* DATE **6-7-2018**

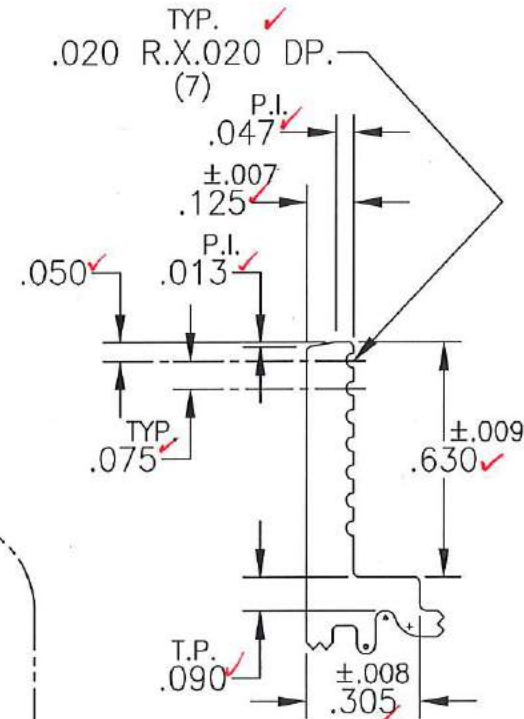

DIE NO.	14028
8" PRESS	
BKR. NO.	11X4
BOLS. NO.	
FDR. PLT.	11X1
EXT. RATIO	47.57
.025 R.-(•)	(4)
.027 R.-(•)	(1)
.045 R.-(•)	(3)
.070 R.-(•)	(4)
FULL R.-(•)	(6)

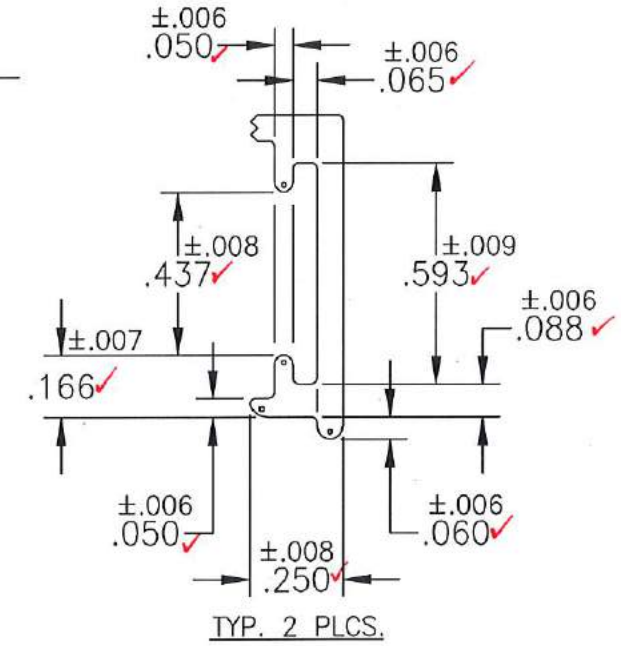
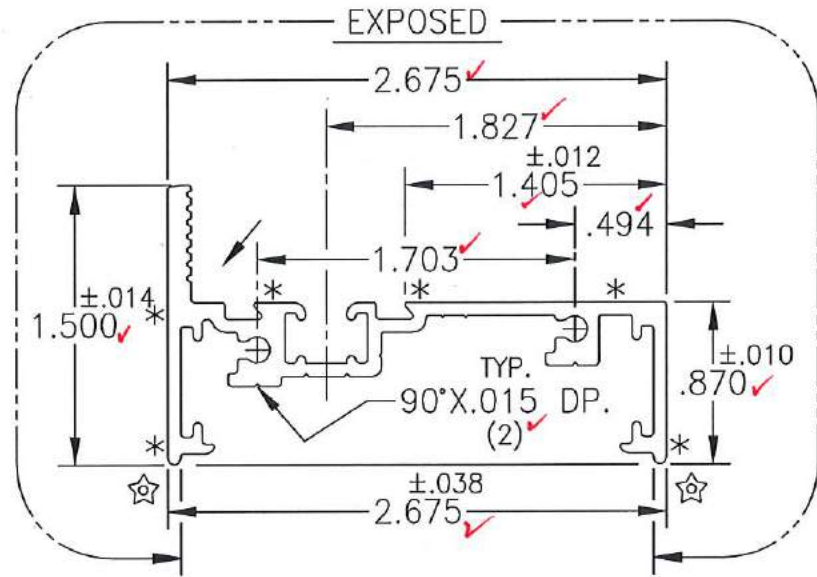
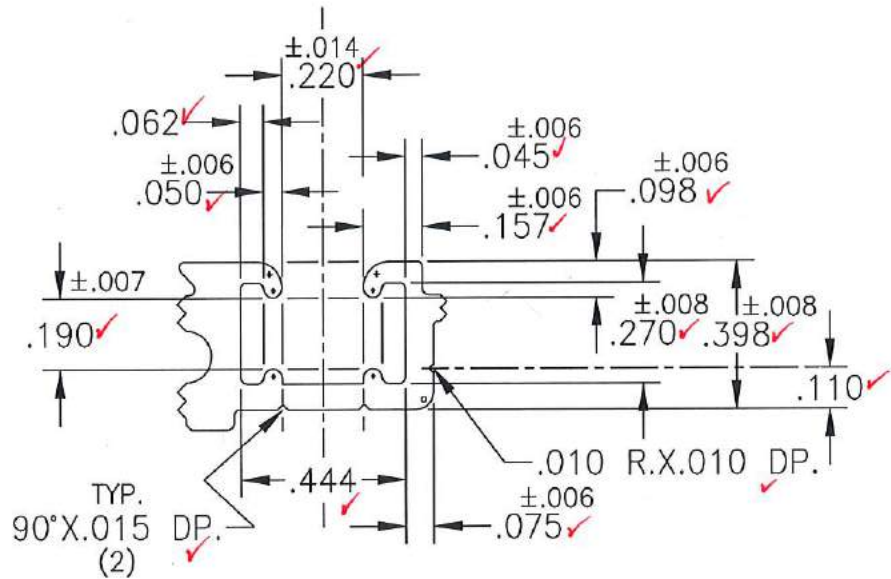

<b>intertek</b> Total Quality Assured.	Report #:	J3067.01-801-44
	Date:	03/05/19
	Verified by:	J.Crump

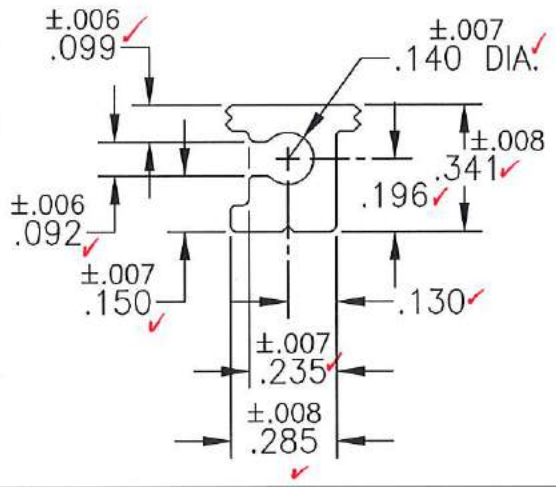
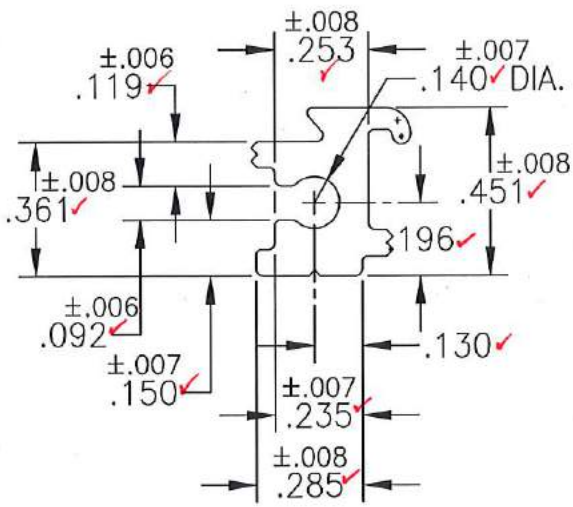
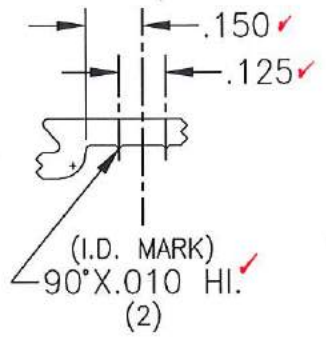

- NOTES: ±.006
- .070 TYP. WALL THKN. EXCEPT AS NOTED.
  - BREAK SHARP CORNERS AT .015 R.

DIE NO. 14028

REVISION			
ALUMINUM ASSOCIATION STANDARD TOLERANCES TO APPLY UNLESS OTHERWISE SPECIFIED			
EST. AREA	.579	TOTAL PERIM.	14.823
EST. WT./FT.	.716	CIRCLE SIZE	3.04
OUTSIDE PERIM.	14.823	DATE:	04-23-18
		HOLES	2
		DRAWN BY:	M.MARKULY
		PREF. PRESS	8"
		SCALE	FULL F

<b>tel</b> EXTRUDERS A DIVISION OF TOWER EXTRUSIONS, LTD.			
NAME <b>RAM INDUSTRIES</b>			
PART NO.		DWG. NO.	D-042318-06
END USE HPW			
CLASS	SOLID	ALLOY	6063-T5
CAVITY	B-B	DIE NO.	14028

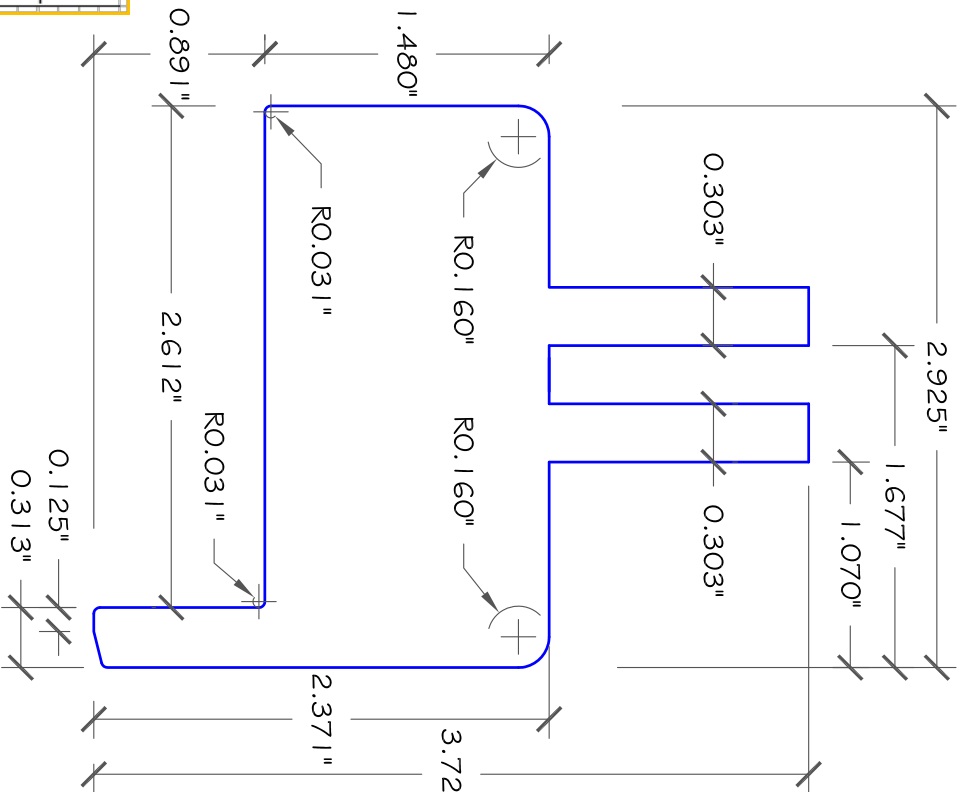
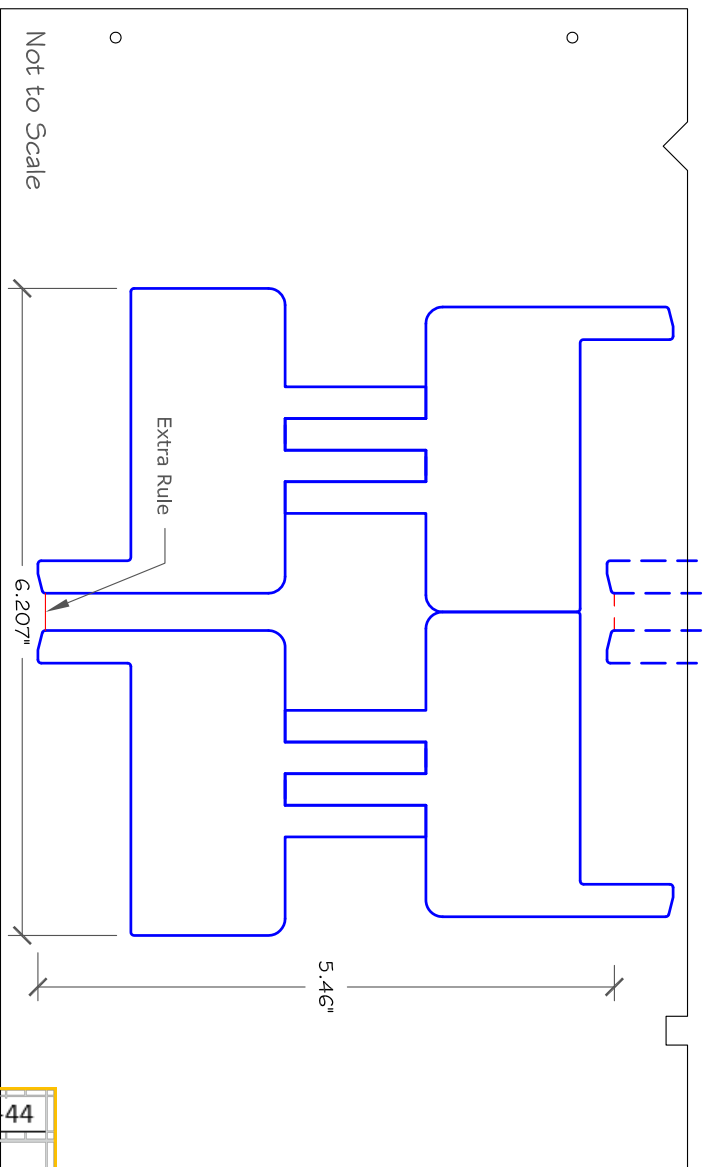

Micrometer:	3.598	PRECO DIE #749	
Progression:	5.350	Board:	5/8" thick wood
Batch / Amount:		Typ/Size:	12" x 20" Preco
Rate / Acceleration:	10 / 5	Rule:	2 pt 0.937" high long dbl cntr bevel
Tons:	16	Punches:	Feed-through
Upstroke:	3.20	/Roll:	
RF2/3 / RF3:	10 / 10	/Box:	
Feed: Before/After:		Box type:	

NOTES

1 SET = 1 Left Hand Gasket  
+ 1 Right Hand Gasket  
Supplied kiss cut on rolls with  
web scrap removed

MATERIAL

1/8" thick 2# XLP w/PSA

Report #:	J3067.01-801-44
Date:	03/05/19
Verified by:	J.Crump

TOLERANCES UNLESS OTHERWISE SPECIFIED		 <b>FRANK LOWE</b> RUBBER & GASKET CO., INC. 44 Hanning Blvd • Spring Lake, MI 49782-4004 831-777-2792 • 800-377-6282 • fax 831-777-2480	
DATE	9-28-2018	SCALE	O-RA1002-HPWCNRGSKTW 1 25
SHEET	1 of 1	HPW Corner Gskt Rev. B	
SHEET WIDTH: 7"		 <b>Ram Industries</b>	





Total Quality. Assured.

## TEST REPORT FOR RAM INDUSTRIES

Report No.: J3067.01-801-44-r0

Date: 03/05/19

1909 10th Street, Suite 100  
Plano, Texas 75074

Telephone: 469-814-0687  
[www.intertek.com/building](http://www.intertek.com/building)

### SECTION 12

#### REVISION LOG

REVISION #	DATE	PAGES	REVISION
0	03/05/19	N/A	Original Report Issue